

Metso

High performance crushing

Nordberg[®]
HP Series[™]
cone crushers





Nordberg® HP Series™ cone crushers

The world's most popular modern cone crushers

Nordberg HP Series cone crushers bring together the optimal combination of crusher speed, throw, crushing forces and cavity design. As the name suggests, these proven and reliable universal crushers deliver High Performance in quarrying and mining applications.

They deliver predictable and consistent production, and they are trouble-free, easy and safe to operate and maintain. Over the years, HP Series cone crushers have become the most popular modern cone crushers in the world, with over 10,000 machines installed globally.

High performance in any application

HP cone crushers are highly adaptable making them truly universal crushers. This means that the same crusher model can be used for any type of application including everything from coarse to extra-fine applications, from aggregates to mining operations. They have a wide range of speed, feed and cavity options, so you can set them up for different roles including secondary, tertiary and quaternary crushing applications.

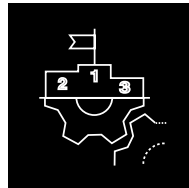

Universal crushers
for all applications

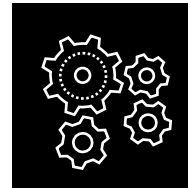

Proven and predictable
production



High performance
in any application

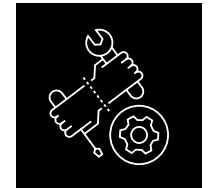

Trouble free, easy and safe
to operate and maintain



Contents

Nordberg® HP Series™ cone crushers	2
World's most popular modern cone crusher	2
High performance in any application	2
Proven and predictable production	4
Trouble free, easy and safe to operate and maintain	4
Nordberg® HP Series™ for aggregates	6
Nordberg® HP Series™ for mining	8
Metso IC Series crusher automation	10
Designed to deliver the highest productivity	12
Technical specifications	13
Cavity selection guide	14
Parts and services	16
Nordberg HP cone crusher installed base by continent	18
Case stories	19

Proven and predictable production

HP Series cone crushers provide predictable and consistent capacity, end product size, gradation and shape, making them a safe choice for aggregates and mining processes. The crusher setting is mechanically fixed while crushing and it is secured by dual-acting cylinders with a high hold-down force to ensure stable end product grading and flow into the next process stages.

In addition, the HP Series has a spiderless design. This is especially beneficial in the secondary stage because it significantly reduces the risk of blockage to ensure an unrestricted flow of feed material into the crusher cavity.

The Nordberg® HP Series™ cone crusher product family includes altogether nine models.

- HP100
- HP300
- HP400
- HP500
- HP900
- HP3
- HP4
- HP5
- HP6



Trouble free, easy and safe to operate and maintain

Ease of use is built-in to the HP Series and the design makes maintenance tasks quick, convenient and safe. The crusher is easy to open, it has a very effective tramp-release system, and it clears the cavity efficiently.

With the HP Series, you can rotate the bowl of the crusher open for easy liner changes using the hydraulic motor. The hydraulic motor also rotates the bowl to adjust the crusher setting.

The tramp-release function is efficient and highly reactive to ensure instant opening in case of overload, instant recovery and continuous operation. The large clearing stroke allows uncrushable objects to pass through the crusher cavity.

The large clearing stroke, together with the double-acting hydraulic hold-down cylinders, ensures quick, easy and safe clearing of the cavity in case the crusher stops under load due to any unexpected reason, for example due to power failure in the electric grid. In addition, all the main components can be accessed from the top for easy servicing.



Aggregates



- Exact final product size
- Closed circuit operation
- Excellent end product shape
- Yield of certain fractions

Universal crushers for quarrying and mining applications

- High throughput
- Easy maintenance
- High production
- Application flexibility

Mining

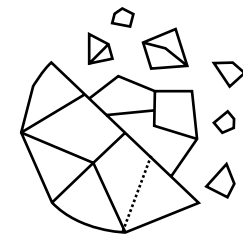

- Maximum reduction ratio for downstream processes
- Open circuit processes

The Nordberg® HP Series™ for aggregates

When you need a crusher for aggregates production, the Nordberg HP Series cone crushers are the ideal choice. The HP Series is well known for its great performance, in terms of its high throughput capacity, high reduction and high end product quality.

And, with our wide product range, we can offer you a cone crusher that meets your needs for any size of application from very specific small scale flows and re-crushing circuits up to super or mega quarry flows. HP series cone crushers are an excellent fit for any stationary, mobile and portable applications.



- Consistent end-product size
- High reduction ratio
- For open and closed circuits
- For all types of end product



Reactive machine protection

The HP Series is designed to ensure high availability and to minimize downtime. Dual acting hydraulic tramp release cylinders protect the crusher against overloading and for example let the tramp iron pass through the crusher, and if needed they provide a large clearing stroke to quickly clear the crushing cavity.

The double-acting tramp-release cylinders linked with the accumulators make the tramp-release system extremely reactive and ensure instant recovery in case the crusher opens due to overloading for example due to uncrushable material in the feed.

Excellent product quality

The HP Series is also flexible and can be installed in a range of applications throughout your operations. It is not specific to just secondary or tertiary stages, like other cone crushers, so it allows the same crusher model to be used in different crushing stages. This can be done throughout the process to minimize differences and reduce spare part requirements. In addition when you use HP cone crushers in multiple crushing stages within the plant, you can apply the same reliable, well known and proven technology in different crushing stages with same service and maintenance procedures as well as same tools and lubricants.

Overall, the performance of HP Series cone crushers has exceeded the expectations of many of our aggregates customers. This is thanks to its proven reliability, as well as consistent and predictable throughput capacity and end product gradation.



The Nordberg® HP Series™ for mining

Metso's Nordberg HP Series cone crushers are ideal for many different mining applications. In mines, cone crushers are typically needed for crushing to obtain the maximum size reduction ratio and they typically focus on producing material for the

downstream process. They are most commonly used in secondary and tertiary applications when maximum material size reduction in an open circuit is required. Nordberg HP Series cone crushers provide high productivity with a smaller plant footprint.



- High availability
- High productivity
- Cost efficiency
- Application flexibility



High availability

The HP Series is designed to ensure high availability and minimize downtime. Dual-acting hydraulic tramp-release cylinders let the crusher pass tramp iron, and if needed they provide a large clearing stroke to quickly clear the crushing cavity.

Metso also provides an optional offline oil filtration system that maintains the good quality of oil and extends the oil change interval significantly.

For different process stages

The HP Series is flexible and can be installed in a range of applications throughout your operations. It is not specific to just secondary or tertiary stages, like other cone crushers, so it allows the same crusher model to be used in different crushing stages. This can be done throughout the process to minimize differences and reduce spare part requirements. In addition, when you use HP cone crushers in multiple applications, you will be able to rely on a single supplier to provide support throughout your operation, with the same reliable technology, the same service and maintenance procedures, as well as the same lubricants and tools.

Overall, the performance of HP Series cone crushers has exceeded the expectations of many of our mining customers. This is thanks to the efficient distribution of force in the chamber, which gives them high capacity, excellent crushing dynamics and a high reduction ratio, with consistent and predictable results.



HP cone crushers are available with optional Metso IC Series™ crusher automation

HP Series cone crushers are available with optional IC70C crusher automation to optimize and monitor crushing with the aim of achieving the best performance, protection and safety in the crushing process. IC70C crusher automation is provided as a complete package, including fully automated lubrication and hydraulic circuit controls, hydraulic

unit motor starters and electrical cabinets. The proven and tested software can be set up for application specific conditions, and the whole system is not just easy to install and commission, it's easy to use, too. In addition, the equipment can be controlled by remote control for improved safety and comfort.



- Best performance
- Best protection
- Trends follow-up
- Alarm log for traceability



Consistent performance

Crushing optimization helps to provide constant throughput at all times. IC crusher automation provides instant process information to the operator and Metso Metrics makes key performance indicators available anywhere, anytime.

The automatic feed rate control helps to maintain the optimal material level in the crusher, which helps you to achieve and maintain the best performance at all times.

HP cone crushers can also be delivered without crusher automation and operated manually or directly through plant automation.

Remote control improves operator safety and comfort

The equipment can be centrally controlled from the safety and comfort of a control room with the help of remote control. This minimizes the need to move around the quarry and limits exposure to traffic, dust and noise. The integrated web-based display is easy to use and can be connected from the existing control room PC.

Continuous monitoring and control minimize risks

Metso IC automation helps to prevent costly downtime by monitoring lubrication, temperatures, RPM and other key parameters in your HP cone crusher. The protection is activated in steps, starting from informative warnings and progressing to limiting the feed material coming into the crusher, and eventually shutting down the crusher to protect the crusher whenever needed.

Nordberg® HP Series™ cone crushers

Designed to deliver the highest productivity

The HP range includes features which are proven to ensure reliability and productivity, while minimizing downtime in aggregate and mining applications. These include a hydraulic motor for precise wear compensation and setting adjustments and quick and simple liner changeout, proven liner retention technology and excellent wear protection of crusher components.

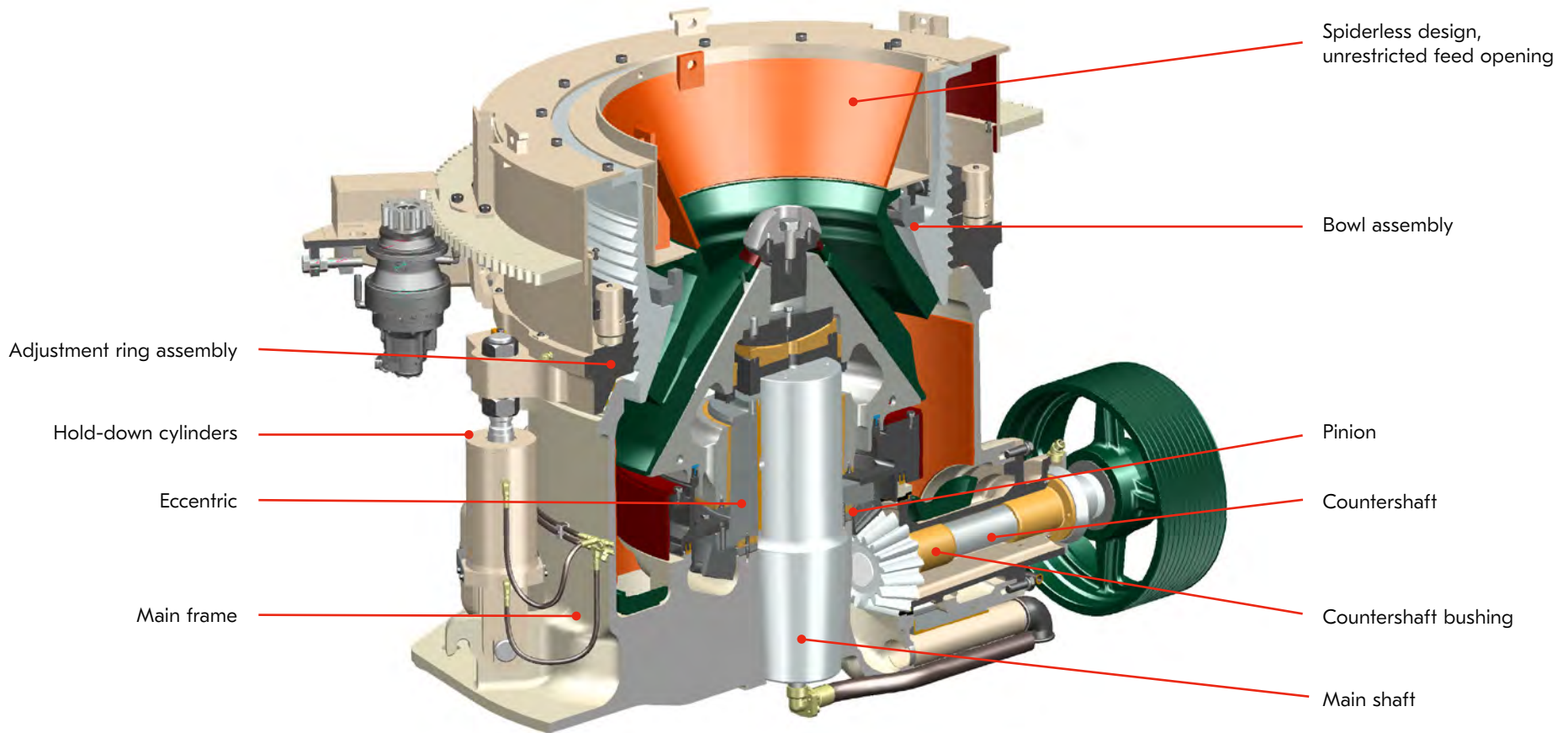

Heavy-duty design

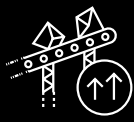

High capacity

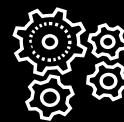

Easy to operate



Cost-efficient maintenance and operations

Technical specifications Nordberg® HP Series™ cone crushers

	HP100™	HP300™	HP400™	HP500™	HP900™	HP3™	HP4™	HP5™	HP6™
Head diameter	735 mm (29")	1,120 mm (44")	1,320 mm (52")	1,520 mm (60")	1,780 mm (70")	1,000 mm (39")	1,120 mm (44")	1 250 mm (49")	1,400 mm (55")
Power	90 kW (125 hp)	220 kW (300 hp)	315 kW (400 hp)	355 kW (500 hp)	700 kW (900 hp)	250 kW (350 hp)	315 kW (400 hp)	370 kW (500 hp)	500 kW (650 hp)
Total crusher weight	6,470 kg (14,300 lbs)	18,100 kg (39,900 lbs)	25,600 kg (56,400 lbs)	37,000 kg (81,600 lbs)	77,960 kg (171,870 lbs)	16,100 kg (35,600 lbs)	24,200 kg (53,400 lbs)	29 000 kg (64 000 lbs)	44,550 kg (98,200 lbs)
Feed opening	150 mm (5 7/8")	241 mm (9 1/2")	304 mm (12")	351 mm (13 4/5")	356 mm (14")	220 mm (8 3/4")	252 mm (9 7/8")	317 mm (12 1/2")	331 mm (13")
Capacity up to	155 Mtph (170 Stph)	440 Mtph (485 Stph)	630 Mtph (700 Stph)	790 Mtph (870 Stph)	2,000 Mtph (2,204 Stph)	388 Mtph (427 Stph)	555 Mtph (610 Stph)	600 Mtph (661 Stph)	790 Mtph (870 Stph)

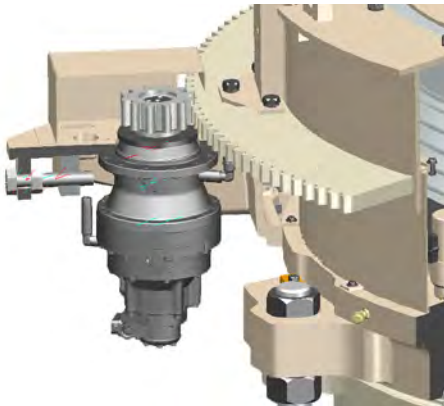

Hydraulic motor for setting adjustment and for opening the crusher for service and liner change

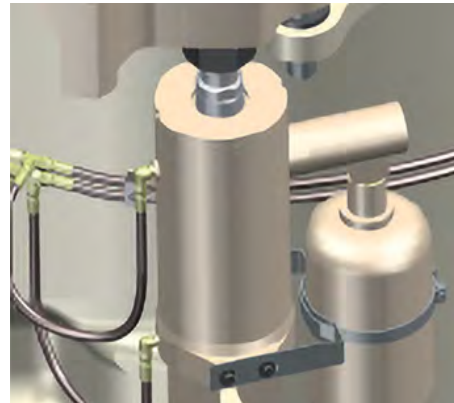

Instant reactivity and recovery in case of overload thanks to accumulators connected to the tramp release cylinders

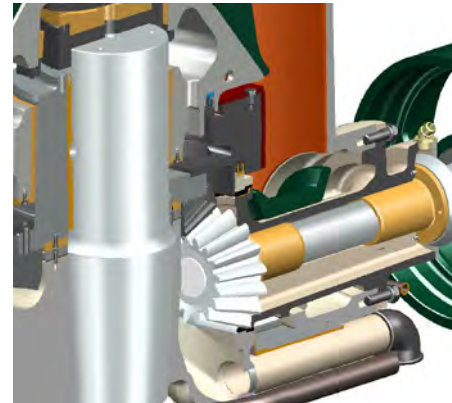

High-performance non-contact labyrinth seals



Tramp release system with large clearing stroke for quick, safe and easy cavity clearing in case the crusher stops under load for any reason

Nordberg® HP Series™ cone crushers

A wide selection of cavities

Select the right cavity for your application

The HP Series is available with a wide variety of different cavities, which makes them easy to adapt for any application. You can select the cavity easily, based on feed size and the cavity-specific closed side feed opening.



Cavity selection guide

Crusher size	Cavity	Minimum setting				Feed opening			
		HP3™	HP4™	HP5™	HP6™	HP3™	HP4™	HP5™	HP6™
	Extra fine	8 mm (0.31")	8 mm (0.31")	6 mm (0.24")	9 mm (0.35")	18 mm (0.78")	67 mm (2.64")	50 mm (2.00")	52 mm (2.05")
	Fine	11 mm (0.43")	10 mm (0.39")	10 mm (0.39")	13 mm (0.52")	95 mm (3.74")	116 mm (4.55")	130 mm (5.10")	106 mm (4.17")
	Medium	15 mm (0.59")	16 mm (0.63")	20 mm (0.79")	20 mm (0.79")	156 mm (6.15")	158 mm (6.22")	195 mm (7.70")	196 mm (7.71")
	Coarse	20 mm (0.79")	25 mm (1.00")	25 mm (1.00")	25 mm (1.00")	183 mm (7.20")	203 mm (7.99")	252 mm (9.90")	279 mm (10.98")
	Extra coarse	25 mm (1.00")	28 mm (1.10")	30 mm (1.20")	30 mm (1.20")	200 mm (7.89")	237 mm (9.93")	312 mm (12.30")	328 mm (12.91")

Nordberg® HP Series™ cone crushers

Cavity selection guide

Crusher size	Cavity	Standard		Short head	
		Minimum setting "A"1	Feed opening "B"2	Minimum setting "A"1	Feed opening "B"2
HP100™	Extra fine			6 mm (0.24")	14 mm (0.55")
	Fine			9 mm (0.35")	74 mm (2.91")
	Medium			9 mm (0.35")	72 mm (2.83")
	Coarse	13 mm (0.51")	100 mm (3.94")		
	Extra coarse	17 mm (0.67")	141 mm (5.55")		
HP300™	Extra fine			6 mm (0.24")	25 mm (0.98")
	Fine	13 mm (0.51")	107 mm (4.21")	6 mm (0.24")	22 mm (0.87")
	Medium	17 mm (0.67")	150 mm (5.91")	8 mm (0.31")	53 mm (2.09")
	Coarse	19 mm (0.75")	211 mm (8.31")	10 mm (0.39")	77 mm (3.03")
	Extra coarse	25 mm (0.98")	233 mm (9.17")		
HP400™	Extra fine			6 mm (0.24")	52 mm (2.05")
	Fine	14 mm (0.55")	111 mm (4.37")	6 mm (0.24")	51 mm (2.00")
	Medium	20 mm (0.79")	198 mm (7.80")	8 mm (0.31")	52 mm (2.05")
	Coarse	25 mm (0.98")	252 mm (9.92")	10 mm (0.39")	92 mm (3.62")
	Extra coarse	30 mm (1.18")	299 mm (11.77")		
HP500™	Extra fine			6 mm (0.24")	53 mm (2.09")
	Fine	16 mm (0.63")	133 mm (5.24")	8 mm (0.31")	52 mm (2.05")
	Medium	20 mm (0.79")	204 mm (8.03")	10 mm (0.39")	57 mm (2.24")
	Coarse	25 mm (0.98")	286 mm (11.26")	13 mm (0.51")	95 mm (3.74")
	Extra coarse	30 mm (1.18")	335 mm (13.19")		
HP900™	Extra fine	16 mm (0.63")	187 mm (7.36")		
	Fine	19 mm (0.75")	219 mm (8.62")	9 mm (0.35")	33 mm (1.30")
	Medium	19 mm (0.75")	267 mm (10.51")	10 mm (0.40")	92 mm (3.62")
	Coarse	25 mm (0.98")	297 mm (11.69")	13 mm (0.51")	155 mm (6.10")
	Extra coarse	32 mm (1.26")	353 mm (13.90")		

Parts and services

Genuine Metso OEM wear and spare parts are the best choice to minimize maintenance issues and increase longevity. Our global distribution logistics network ensures that Metso OEM spare and wear parts are available when you need them. With both standard and engineered-to-order parts, Metso can ensure that you have the support your crushers need.

Our service offering ensures that you get the best out of your HP cone crusher. This includes maintenance and repair services, equipment upgrades and retrofits, process optimization and controls, and Life Cycle Services. Together with our expertise, these services can help you reach your production goals, improve your crushing process and extend the productive lifetime of your cone crusher.



- Genuine Metso parts
- Reliable availability
- Standard and engineered-to-order
- Available through Metso's global network



- A portfolio of expert services
- Maintenance and repairs
- Upgrades and retrofits
- Process optimization and control
- Life Cycle Services

The Nordberg HP cone crusher installed base by continent

Well over 10,000 Nordberg HP cone crushers have been delivered around the world since 1989. They have proven their reliability and performance in numerous quarrying and mining applications as secondary, tertiary and quaternary crushers in stationary, mobile and portable crushing plants.

HP cone crushers are truly universal crushers and they can be adapted for different customer requirements. These range from size reduction to production of different materials, such as aggregates for asphalt or concrete, railroad ballast and manufactured sand.

There are many reasons why our customers trust HP cone crushers in their production. These include excellent performance and reliability, ability to produce the desired high-quality end product, long lasting wear parts and cost-efficiency, as well as the ease of use and safety.

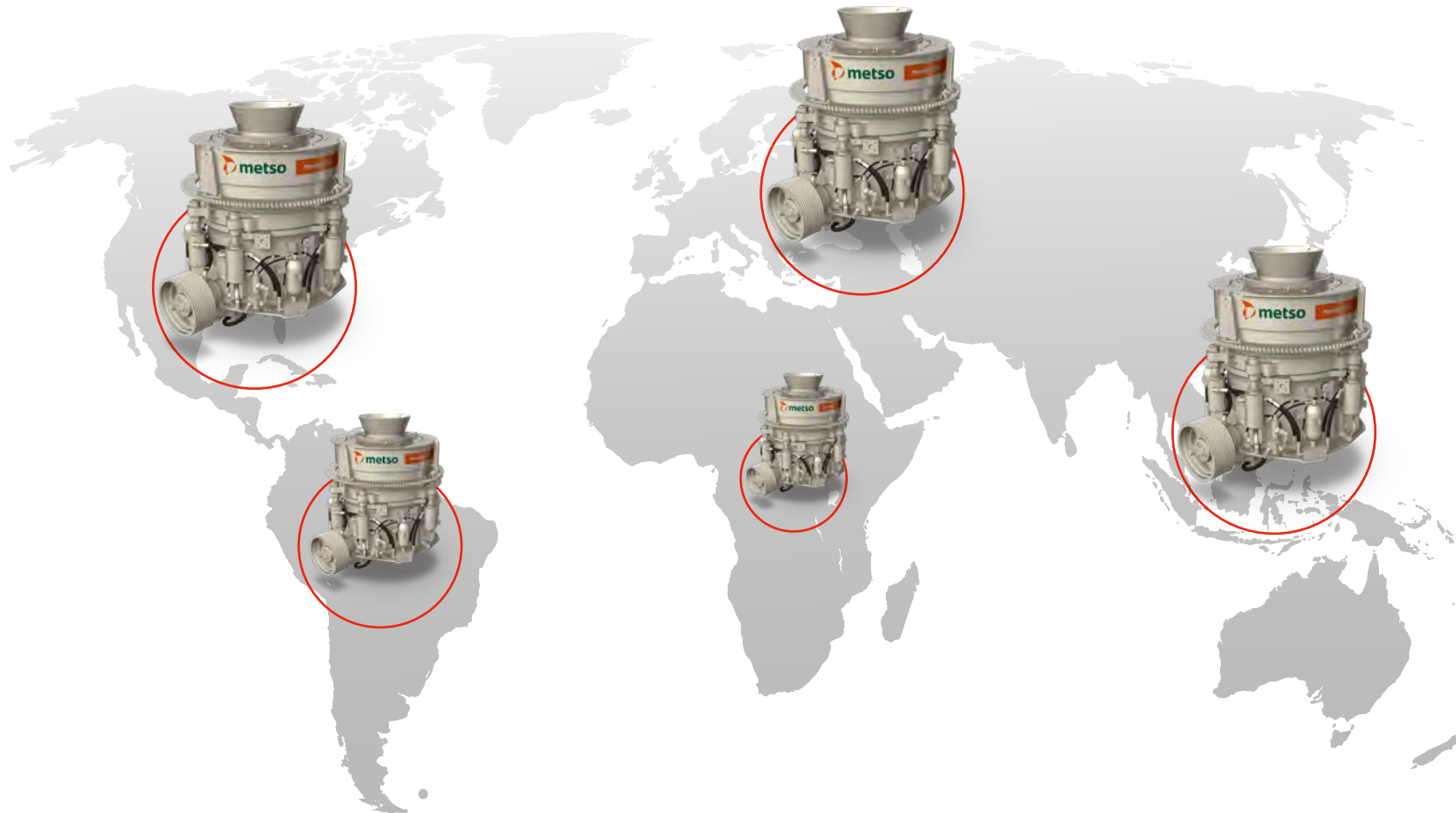

Case Story, Ofitas de Santutis, Spain



"We doubled the plant capacity to 800 tonnes per hour. We're extremely happy with the solution they provided. The whole plant brings us the desired results in response to the changes demanded by the market."

Mr. Carlos Fernandez
Engineer manager of the Ofitas de San Felices quarry

Challenge: Improve plant versatility to meet changing market demands and production capacity needs for high-quality sand, gravel and ballast

Solution: One Metso Lokotrack® LT125™ primary mobile jaw crusher, two Nordberg® HP4 cone crushers working as secondary and tertiary crushers

Result: Improved versatility, plant capacity doubled to 800 tonnes per hour

Case Story, Beira Rio, Brazil



"We take a preemptive, planned approach and we look after our assets in order to ensure their performance and availability. The new crushing plant has allowed us to meet our demand within – and even exceeding – our standard of quality."

Mr. Artur Braghetto Barillari
Company owner, Beira Rio

Challenge: Increase mineral aggregates production from basalt rock, while maintaining quality

Solution: A new crushing plant utilizing one Nordberg C120 jaw crusher and two HP300 cone crushers

Result: 70-80% increase in production, improved end-product quality, reduced power consumption

